

HIGH PURITY NORTHWEST INC.



Removes moisture to <20ppm & <10ppm on transformer oil. Particulate removal to any required ISO cleanliness code.

**THERMO-VAC
SUPER MINI
OIL PURIFIER**
VACUUM DEHYDRATOR & DEGASSER

www.highpuritynorthwest.com

sales@hpnwinc.com

Local: (206) 782-2388 | Toll free: (866) 220-5118

2031 196th St. SW Ste. B102, Lynnwood, WA 98036



THERMO-VAC SUPER MINI VACUUM DEHYDRATOR

The Thermo-Vac Super Mini is a compact, industrial grade, and cost effective system for removal of water, dissolved gases and particulate matter from oil reservoirs up to 200 gallons. It utilizes the principle of vacuum dehydration to thoroughly remove free and dissolved moisture and then filters the oil by way of an absolute rated filter available in ratings of 1, 3, 6, 12, and 25 microns. This highly portable system is an extremely reliable way to purify industrial oils such as, lubricating oils, hydraulic fluids, speed control oils, insulating oils, and phosphate ester and other fire resistant fluids.

OPERATION

System vacuum draws the oil/fluid into the unit through an inline heater where it is heated up to 140-150°F (66°C). The fluid then flows through a dispersal element (pleated or permanent packed), which is located inside the vacuum tower. Oil flows inside out through the dispersal element and is exposed to vacuum, normally 25" -28" hg (635mm HG). The boiling point of water is below the fluid temperature at this pressure. Water and gasses are boiled off. An outlet pump removes the dehydrated/degassed oil from the bottom of the vacuum chamber and pumps it through a particulate filter as it exits the system.

Fluid level in the vacuum tower is maintained automatically.

A recirculation valve, located on the discharge piping, can be used to divert 0-100% of the oil back to the system inlet. This valve is useful with high viscosity fluids or in conditions where the outlet pump is pumping oil out of the vacuum chamber faster than the vacuum can draw oil in such as in cold starts with viscous oils.

The mechanical components of the system are uncomplicated and require little or no routine maintenance. All components can be field repaired or replaced without special tools.

OPTIONS

Laser Particle Counter with Moisture Monitor
Transformer Oil Moisture Monitor
Special Seals

APPLICATIONS

- Hydraulic Oils
- Lubricating Oils
- Gear Oils
- Neat Cutting Oils
- Transformer Oils
- Insulating Fluids
- Stamping Oils
- Phosphate Ester Fluids
- Skydrol
- Paper Machine Oils
- Turbine Oils
- Heat Treating Oils
- Compressor Oils
- Cutting Oils

VOLTAGE	MAXIMUM ALLOWABLE HEAT
120V/1PHASE/60Hz	1.5 KW
220V/1PHASE/60HZ	3 KW
230V/3PHASE/60HZ	5 KW
480V/3PHASE/60HZ	7 KW



THERMO-VAC SUPER MINI

- 3 GPM (11 LPM)
- 3/4" NPT Inlet/Outlet Connections
- 15 CFM @ 28" Hg. Rotary Vane Vacuum Pump
- Vacuum Level is Adjustable

THERMO-VAC SUPER MINI FLOW DIAGRAM

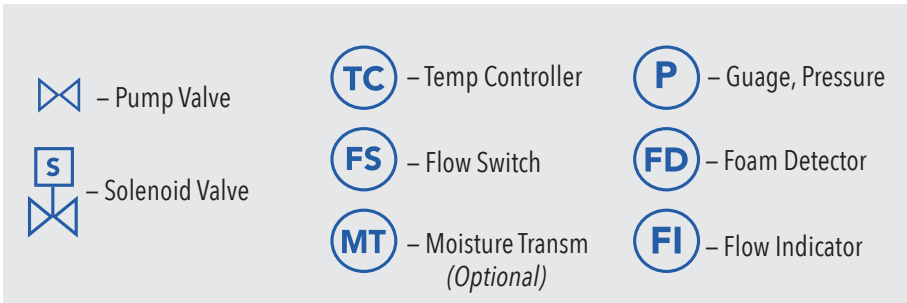
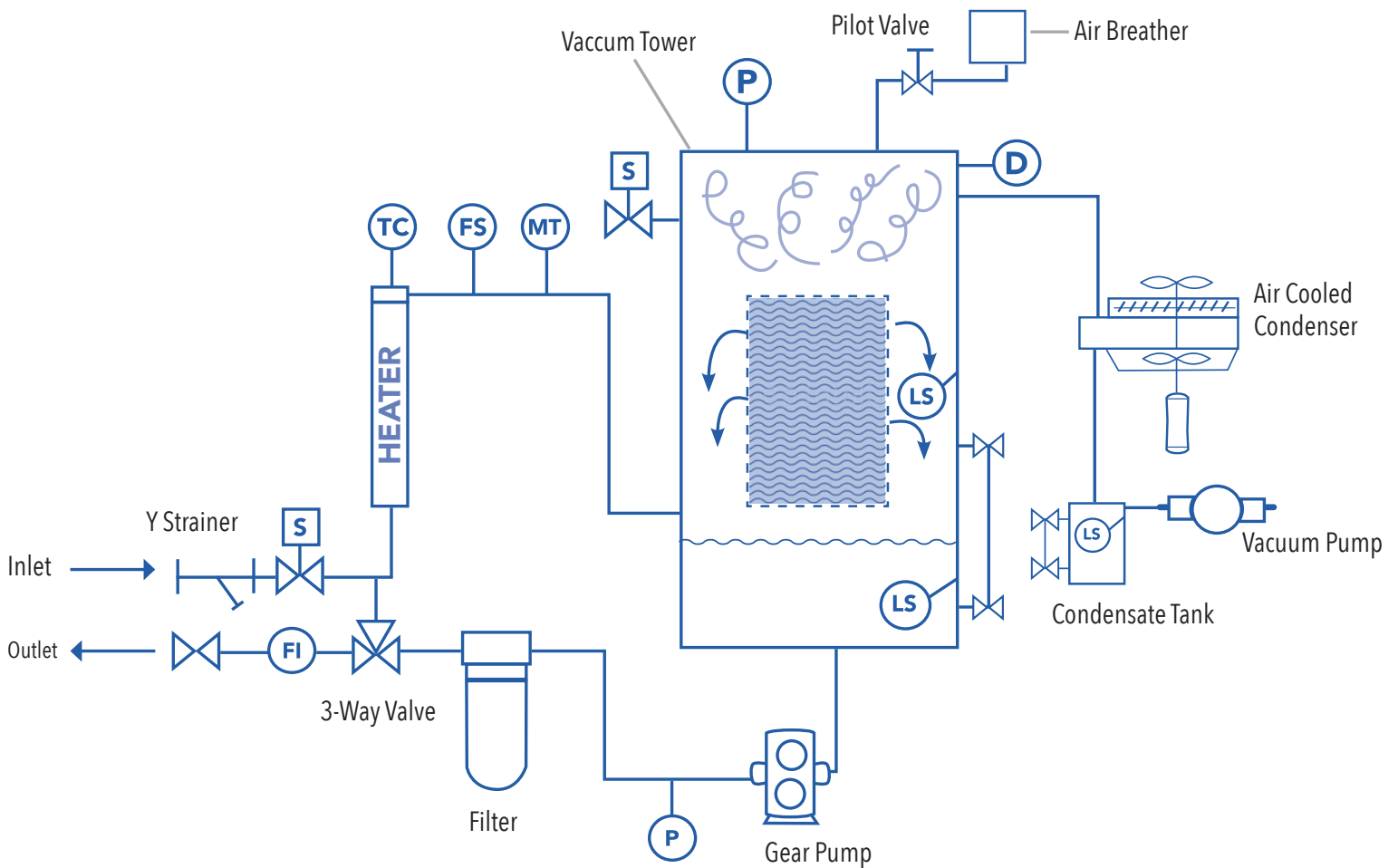

THERMO-VAC SUPER MINI NOMENCLATURE

